

# Outdoor Condenser: 1.5-5 Tons 13 SEER Horizontal Discharge 410A



## User's Manual and Installation Instructions

These units have been designed and tested for capacity and efficiency in accordance with ARI Standards for use with a wide variety of fossil fuel furnaces, electric furnaces, air handlers, and evaporator coil combinations.



These instructions are primarily intended to assist qualified individuals experienced in the proper installation of heating and/or air conditioning appliances. Some local codes require licensed installation/service personnel for this type of equipment. Read all instructions carefully before starting the installation.

# Contents

1. General Information.....	2
2. Safety Considerations .....	2
3. Site Preparation .....	2
4. Install the Outdoor Unit .....	3
5. Install the Indoor Unit.....	3
6. Connecting Refrigerant Tubing.....	3
7. Making Electric Connection.....	4
8. Start-up and Check-up.....	4
9. Refrigerant Charging and Adjustment.....	5
10. Air Release.....	6
11. Wiring Diagrams.....	7
12. Outline Dimensions of Units.....	8

## 1. GENERAL INFORMATION

Read the following instructions completely before performing the installation.

**Condensing Unit Section** — Each condensing unit is shipped with a refrigerant charge adequate to operate the outdoor section with an indoor matching coil or air handler and 15 feet of refrigeration line.

**NOTE: DO NOT USE ANY PORTION OF THE CHARGE FOR PURGING OR LEAK TESTING.**

Matching coils and air handlers are shipped with a small holding charge to pressurize them to keep out contaminants. To release the pressure, read the indoor section of the installation instructions carefully.

**Liquid and Suction Lines** — Refrigerant grade copper tubing should be used when installing the system. Refrigerant suction line tubing should be fully insulated.

**Field Connections for Electrical Power Supply** — All wiring must comply with the current provisions of the “National Electrical Code” (ANSI C1.) and with applicable local codes having jurisdiction. Size of electrical conductors and circuit protection must be in compliance with the information listed on the outdoor unit data label.

## 2. SAFETY CONSIDERATIONS

**Pressures Within the System** — Split System Air Conditioning equipment contains liquid and gaseous refrigerant under pressure. Installation and servicing of this equipment should be accomplished by qualified, trained personnel thoroughly familiar with this type of equipment.

Under no circumstances should the homeowner attempt to install and/or service the equipment without proper supervision from trained and qualified service personnel.

**Labels, Tags, Precautions** — When working with this equipment, follow all precautions in literature, on tags, and on labels provided with the equipment. Read and thoroughly understand the instructions provided with the equipment prior to performing the installation and operational checkout of the equipment.

## 3. SITE PREPARATION

**Unpacking Equipment** — Remove the cardboard carton.

**Inspect for Damage** — Inspect the equipment for damage prior to installing the equipment at the job site. Ensure coil fins are straight and, if necessary, comb fins to remove flattened and bent fins.

**Preferred Location of the Outdoor Unit at the Job Site** — Conduct a survey of the job site to determine the optimum location for mounting the outdoor unit. Overhead obstructions, poorly ventilated areas, and areas subject to accumulation of debris should be avoided. The outdoor unit should be installed no closer than 18 inches from the outside walls of the facility and in an area free from overhead obstructions to ensure unrestricted airflow through the outdoor unit.

**Facility Prerequisites** — Electrical power supplied must be adequate for proper operation of the equipment. The system must be wired and provided with circuit protection in accordance with

local building codes and the National Electrical Code.

**Minimum Circuit Amperage** — Electrical wiring to the equipment must be compatible and in compliance with the minimum circuit amperage listed on the outdoor unit data label.

**Maximum Fuse/Circuit Breaker Size** — Circuit protection for the outdoor unit must be compatible with the maximum fuse/circuit breaker size listed on the outdoor unit data label.

#### 4. INSTALLING THE OUTDOOR UNIT

##### Choice of Outdoor Unit Mounting Positions:

1. Don't install unit near flammable gases or high temperature device.
2. Don't install unit in areas with corrosive atmosphere.
3. Don't install unit near the pavement or in a position where children have access.
4. Leave spaces beside the unit as indicated for good ventilation.
5. Install at area where installation and maintenance is convenient.
6. In order to reduce noise and vibration, unit should be installed firmly.
7. The maximum length of piping is 150 ft. For Liquid lines over 15 ft. distance, add .3 Oz. (3/8") and .6 Oz. (1/2") of refrigerant per linear foot.

All our compressors are tropicalised to ensure efficiency at high temperatures. Even so, we recommend where temperatures exceed 104 F° that the condensing unit is shielded from direct sunlight.

**Slab Mount** — The site selected for a slab mount installation requires a stable foundation and one not subject to erosion. The slab should be level and anchored (if necessary) prior to placing the equipment on the slab.

**Cantilever Mount** — The cantilever mount should be designed with adequate safety factor to support the weight of the equipment, and for loads the mount is subjected to during operation. Installed equipment should be adequately secured to the cantilever mount and leveled prior to operation of the equipment.

**Roof Mount** — The method of mounting should be designed so as not to overload roof structures nor transmit noise to the interior of the structure.

Refrigerant and electrical lines should be routed through suitably waterproofed openings to prevent water leaking into the structure.

##### Mounting Clearance

A minimum of 4 Ft. clearance on the fan outlet should be maintained at all times.

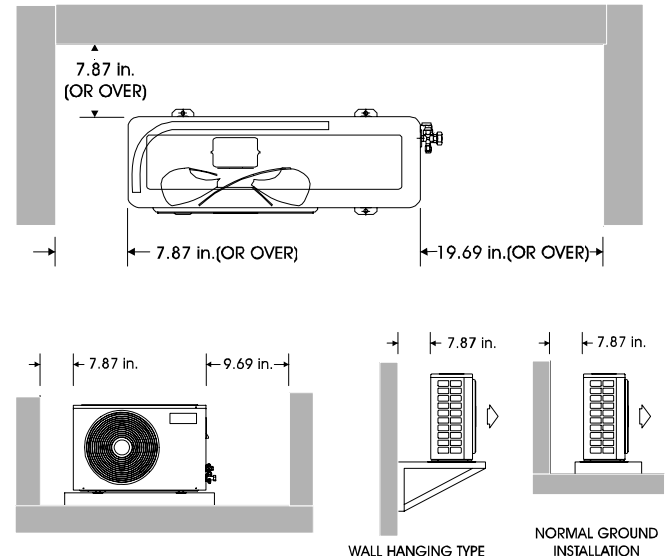

#### 5. INSTALLING THE INDOOR UNIT

The indoor section of the unit should be installed before proceeding with the routing of refrigerant piping. Consult the Installation Instructions of the indoor unit (i.e., air handler, fan coil unit, etc.) for details regarding installation.

#### 6. CONNECTING REFRIGERANT TUBING BETWEEN INDOOR AND OUTDOOR UNITS

**General Information** — Once the outdoor and indoor unit placement has been determined, route the refrigerant tubing between the equipment in accordance with sound installation practices. Refrigerant tubing should be routed in a manner that minimizes the length of tubing and the number of bends in the tubing. Refrigerant tubing should be supported in a manner that the tubing will not vibrate or abrade during system operation. Tubing should be kept clean of foreign debris during installation and installation of a liquid line filter drier is recommended if cleanliness or adequacy of system evacuation is unknown or compromised. Every effort should be made by the installer to ensure that the field installed refrigerant containing components of the system have been installed in accordance with these instructions and sound installation practices so as to insure reliable system operation and longevity. The maximum recommended interconnecting refrigerant line length is 150 feet, and the vertical elevation

difference between the indoor and outdoor sections should not exceed 50 feet.

**Sweat Refrigerant Pipe Fittings:**

Model CCAG-	Recommended Pipe Size		Refrigerant Pre-Charge [lbs]
	Suction	Liquid	
18	5/8"	3/8"	Need
24	5/8"	3/8"	8.93
30	5/8"	3/8"	9.26
36	5/8"	3/8"	9.38
48	3/4"	1/2"	12.5
60	3/4"	1/2"	12.6

**Interconnecting Pipe Size Variations:**

MODEL CCAG	RECOMMENDED							
	15 ft.		30 ft.		50 ft.		65 ft.	
	Liq	Gas	Liq	Gas	Liq	Gas	Liq	Gas
18	Ø3/8	Ø5/8	Ø3/8	Ø5/8	Ø3/8	Ø7/8	Ø3/8	Ø7/8
24	Ø3/8	Ø5/8	Ø3/8	Ø5/8	Ø3/8	Ø7/8	Ø3/8	Ø7/8
30	Ø3/8	Ø5/8	Ø3/8	Ø5/8	Ø3/8	Ø7/8	Ø3/8	Ø7/8
36	Ø3/8	Ø5/8	Ø3/8	Ø5/8	Ø3/8	Ø7/8	Ø3/8	Ø7/8
48	Ø1/2	Ø3/4	Ø1/2	Ø7/8	Ø1/2	Ø1	Ø1/2	Ø1 1/8
60	Ø1/2	Ø3/4	Ø1/2	Ø7/8	Ø1/2	Ø1	Ø1/2	Ø1 1/8

**7. MAKING ELECTRICAL CONNECTIONS**

**Wiring Diagram/Schematic** — A wiring diagram/schematic is located on the inside cover of the electrical box of the outdoor unit. The installer should become familiar with the wiring diagram/schematic before making any electrical connections to the outdoor unit.

**Outdoor Unit Connections** — The outdoor unit requires both power and control circuit electrical connections. Refer to the unit wiring diagram/schematic for identification and location of outdoor unit field wiring interfaces.

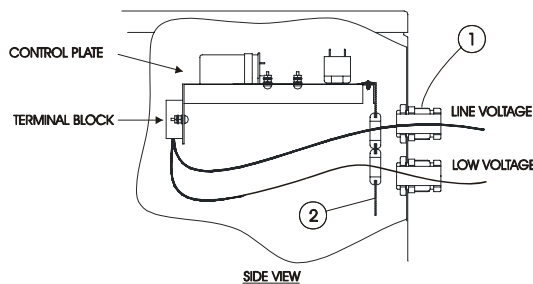

**WARNING**

① When wire the line voltage and the low voltage in the field electric cable wire must to insert through the hole ② (Provided from factory) in order to protect the electric cable wire attached with the pipe.

**Control Circuit Wiring** — The outdoor unit is designed to operate from a 24 VAC control circuit. Control circuit wiring must comply with the current provisions of the “National Electrical Code” (ANSI C1.) and with applicable local codes having jurisdiction.

**Thermostat Connections** — Thermostat connections should be made in accordance with the instructions supplied with the thermostat and with the instructions supplied with the indoor equipment.

**Electrical Wiring** — Electrical wiring must comply with the current provisions of the “National Electrical Code” (ANSI C1.) and with applicable local codes having jurisdiction. Use of rain tight conduit is recommended. Electrical conductors shall have minimum circuit amperage in compliance with the outdoor unit rating label. The facility shall employ electrical circuit protection at a current rating no greater than that indicated on the outdoor unit rating label.

**Electric Data**

MODEL CCAG-	Power V/Ph/HZ	Compressor		Fan	MCA
		RLA	LRA	FLA	AMP.
18	208- 230/1/60	10	48	0.49	15
24		15	58.3	2.27	25
30		15.7	73	2.27	25
36		18.6	79	.49x2	25
48		24.3	117	.49x2	35
60		29.4	134	2.27x2	45

RLA-Rated Load Amp. LRA-Locked Rotor Amp. FLA-Full Load Amp.  
MCA-Minimum Circuit Amp per section NEC 430-24

**Disconnect Switch** — An electrically compatible disconnect switch must be within line of sight of the outdoor unit. This switch shall be capable of electrically de-energizing the outdoor unit.

**Optional Equipment** — Optional equipment requiring connection to the power or control circuits shall be wired in strict accordance with current provisions of the “National Electrical Code” (ANSI C1.), with applicable local codes having jurisdiction, and the Installation Instructions provided with the equipment. Optional Equipment (i.e., liquid line solenoid valves, hard start kits, low suction pressure cutout switch kit, high pressure cutout switch kit, refrigerant compressor crankcase heater, etc.) should be installed in strict accordance with the manufacturer’s Installation Instructions.

**8. START-UP AND CHECKOUT**

**Air Filters** — Ensure air filters are clean and in place prior to operating the equipment.

**Thermostat** — Set the room thermostat function switch to OFF, fan switch to AUTO, and move the temperature set-point to it’s highest setting.

Prior to applying electrical power to the outdoor unit, ensure that the unit has been properly and securely grounded.

Prior to applying electricity to the outdoor unit, check all power supply connections at the breaker panel and at the outdoor unit.

**Outdoor Unit** — Ensure the outdoor coil and front of the unit are free from obstructions and debris, and all equipment access/control panels are in place.

### Functional Checkout:

**Indoor Blower** — Set the thermostat function switch to “Cooling” and the fan switch to ON or MAN. Verify that the Indoor Blower is operating and that airflow is not restricted. Set the fan switch back to Auto.

**Cooling** — Gradually lower the thermostat temperature set point below the actual room temperature and observe that the outdoor unit and indoor blower energize. Feel the air being circulated by the indoor blower and verify that it is cooler than ambient temperature. Listen for any unusual noises. If present, locate and determine the source of the noise and correct as necessary.

**Heating** — If provided with heating equipment, lower the thermostat temperature to the lowest obtainable setting and set the thermostat function switch to “Heating.” The indoor blower and outdoor unit should stop running. Increase the set-point temperature of the thermostat to the maximum setting. Verify that the heating equipment has been energized (i.e., fossil fuel burner operating, etc.) and that the indoor blower energizes after a short period of time. Feel the air being circulated by the indoor blower and verify that it is warmer than ambient temperature. Listen for any unusual noises. If present, locate and determine the source of the noise and correct as necessary.

## 9. REFRIGERANT CHARGING AND ADJUSTMENT

**NOTE:** The Refrigerant Charging Charts are applicable to matched assemblies of our equipment and at listed airflow for the indoor coil. Assemblies of indoor coils and outdoor units not listed are not recommended and deviations from rated airflow or non-listed equipment combinations may require modifications to the expansion device(s) and refrigerant charging procedures for proper and efficient system operation.

**Refrigerant Charging Chart** — Refer to Refrigerant Charging Charts for correct system charging and to Orifice Usage Chart for correct restrictor sizes.

**Optional Equipment** — A functional checkout should be performed in specific accordance with the checkout procedure supplied with the equipment.

**Note:** Do not vent or depressurize unit refrigerant to atmosphere. Remove and recover refrigerant following Ashrae standard HVAC practices.

Two methods to check or adjust refrigerant charge:

### A: Super Heat Method (Cooling, Non-TXV)

1. Operate system at cooling for at least 15 minutes.
2. Measure refrigerant pressure Psc at suction valve service port.
3. Measure suction line temperature Tsc1 by attaching and insulating thermometer probe to suction line close to the service valve.
4. Measure air dry bulb temperature Tod at outdoor condenser inlet.
5. Measure air wet bulb temperature Tiw at indoor evaporator inlet.
6. By using Tod and Tiw in Table A, intersect to get superheat temperature Tsp.
7. By using Tsp and Psc in Table B, intersect to get suction line temperature Tsc2 temperature Tsp.
8. If Tsc1 is higher than Tsc2, add refrigerant and repeat above steps till Tsc1=Tsc2.
9. If Tsc1 is lower than Tsc2, remove refrigerant and repeat above steps till Tsc1=Tsc2.

### B: Subcooling Method (Cooling, TXV)

1. Operate system at cooling for at least 15 minutes.
2. Measure refrigerant pressure Pliq at liquid valve service port.
3. Measure liquid line temperature by attaching and insulating thermometer probe to liquid line close to the service valve.
4. In Table C, by intersecting required subcooling temperature and measured refrigerant pressure Pliq, get required liquid line temperature, at the service valve.

Outdoor Temperature (°F)	Indoor Temperature (°F Drybulb)				
	65	70	75	80	85
115					3
100				5	5
95			5	5	5
90			7	12	18
85		5	10	17	20
80		5	12	21	26
75	5	10	17	25	29
70	5	14	20	28	32
65	13	19	26	32	35
60	17	25	30	33	37

Table A-Superheat Tsp (F) For Fixed Orifice Devices

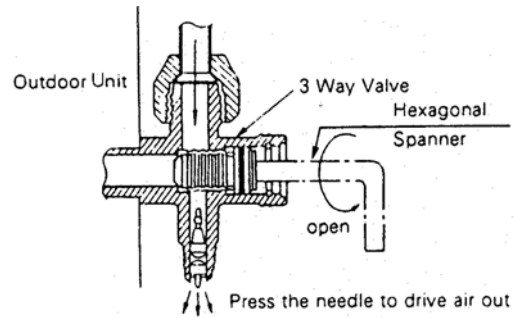

### 10. AIR RELEASE

**Purge the air within the indoor unit and piping from the system by using a vacuum pump.**

1. Release air as the diagram above shows.
2. Shows the vacuum pump operating 15 minutes at least. Read gauge meter and make sure pressure reaches -29.92 in Hg. After ± the vacuum pump is turned off. Please wait a few minutes and check the gauge meter doesn't change reading to confirm no leakage in the piping.
3. Shows locked position.
4. Shows locked position.
5. Please test for leaks with gas detection instrument or soapy water before turning on the system (unit).

Table B-Suction Line Temperature Tsc2 (F)

Superheat	Suction Pressure at Service Port Psc (PSIG)											
Temp. Tsp(F)	105	109	114	118.0	123.0	127.0	132.0	137.0	142.0	147.0	153.0	158.0
0	34	36	38	40	42	44	46	48	50	52	54	56
2	36	38	40	42	44	46	48	50	52	54	56	58
4	38	40	42	44	46	48	50	52	54	56	58	60
6	40	42	44	46	48	50	52	54	56	58	60	62
8	42	44	46	48	50	52	54	56	58	60	62	64
10	44	46	48	50	52	54	56	58	60	62	64	66
12	46	48	50	52	54	56	58	60	62	64	66	68
14	48	50	52	54	56	58	60	62	64	66	68	70
16	50	52	54	56	58	60	62	64	66	68	70	72
18	52	54	56	58	60	62	64	66	68	70	72	74
20	54	56	58	60	62	64	66	68	70	72	74	76
22	56	58	60	62	64	66	68	70	72	74	76	78
24	58	60	62	64	66	68	70	72	74	76	78	80
26	60	62	64	66	68	70	72	74	76	78	80	82
28	62	64	66	68	70	72	74	76	78	80	82	84
30	64	66	68	70	72	74	76	78	80	82	84	86
32	66	68	70	72	74	76	78	80	82	84	86	88
34	68	70	72	74	76	78	80	82	84	86	88	90
36	70	72	74	76	78	80	82	84	86	88	90	92
38	72	74	76	78	80	82	84	86	88	90	92	94
40	74	76	78	80	82	84	86	88	90	92	94	96

Table C: Liquid Line Temperature

Required Sub-cooling Tsb (F)	Liquid Pressure at Service Valve (PSIG)																								
	220	231	242	254	265	278	290	303	316	330	344	359	374	390	406	422	440	457	475	494	513	533	554	575	596
0	76	79	82	85	88	91	94	97	100	103	106	109	112	115	118	121	124	127	130	133	136	139	142	145	148
5	66	69	72	75	78	81	84	87	90	93	96	99	102	105	108	111	114	117	120	123	126	129	132	135	143
10	61	64	67	70	73	76	79	82	85	88	91	94	97	100	103	106	109	112	115	118	121	124	127	130	138
15	56	59	62	65	68	71	74	77	80	83	86	89	92	95	98	101	104	107	110	113	116	119	122	125	133
20	51	54	57	60	63	66	69	72	75	78	81	84	87	90	93	96	99	102	105	108	111	114	117	120	128
25	46	49	52	55	58	61	64	67	70	73	76	79	82	85	88	91	94	97	100	103	106	109	112	115	123

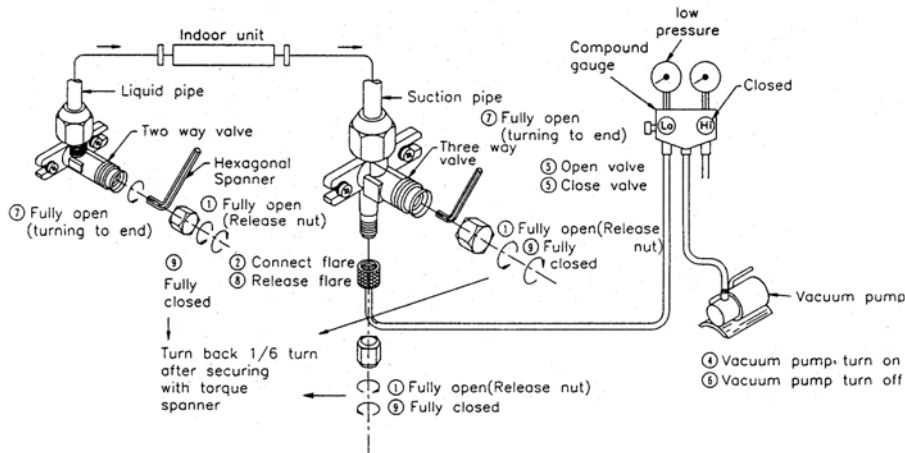

# 11. WIRING DIAGRAMS

## CCAG-18-DFN, CCAG-24-DFN, CCAG-30-DFN

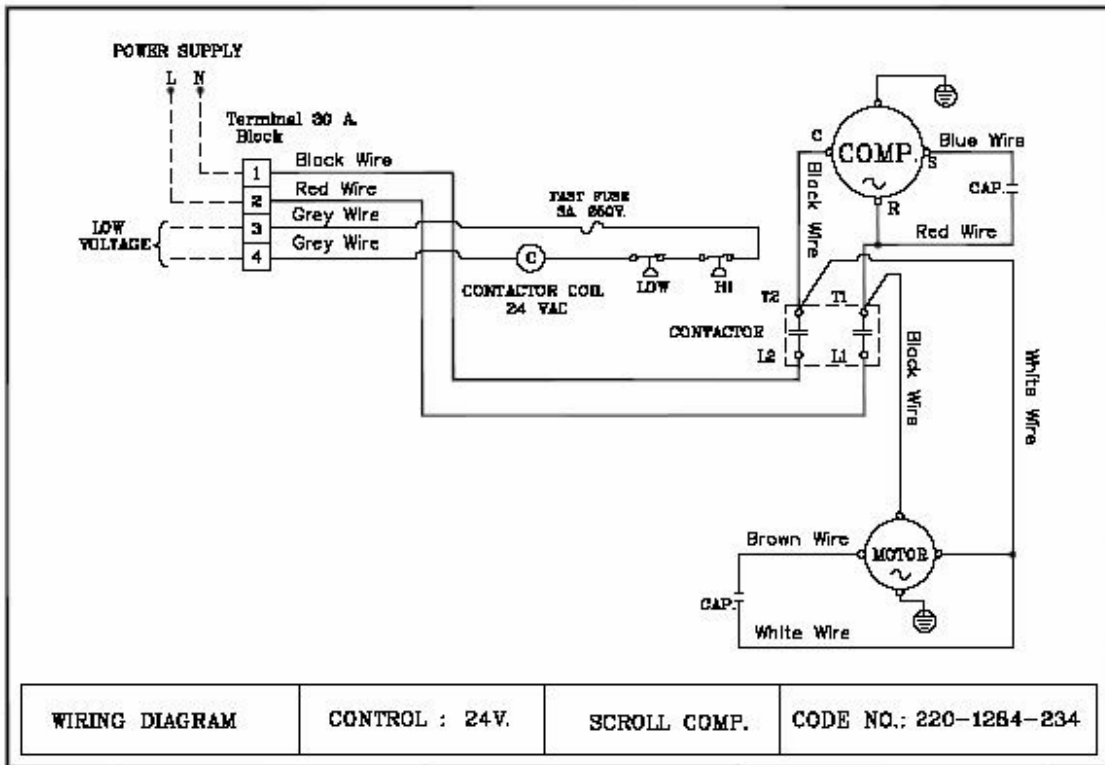

## CCAG-36-DFN, CCAG-48-DFN, CCAG-60-DFN

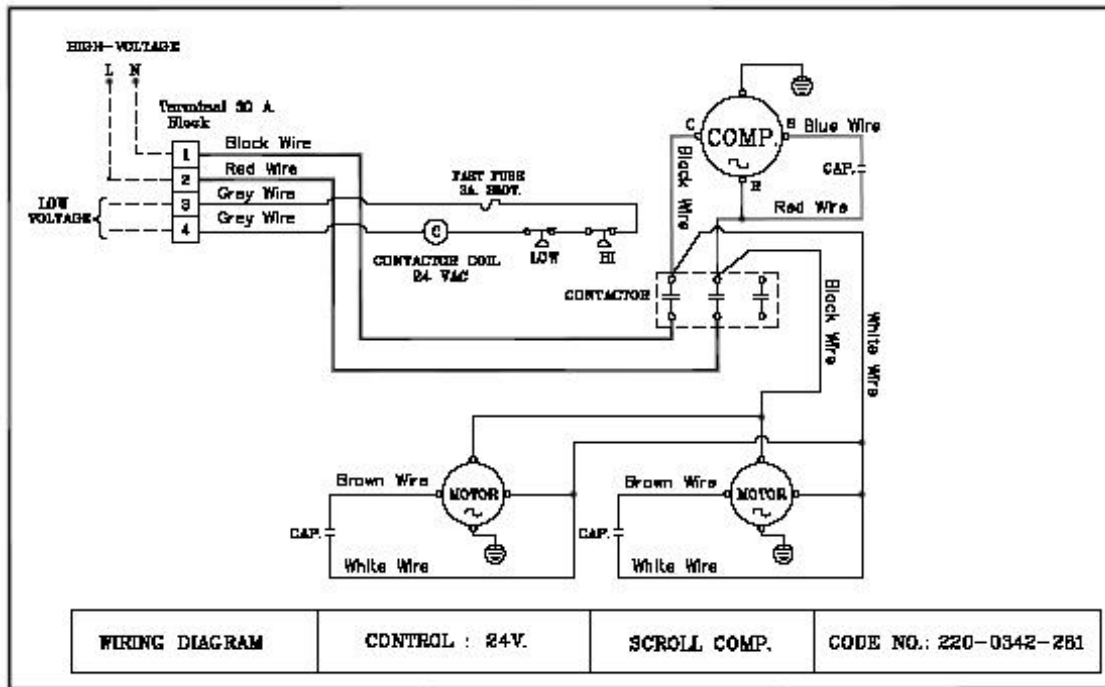

## 12. OUTLINE DIMENSIONS OF UNITS

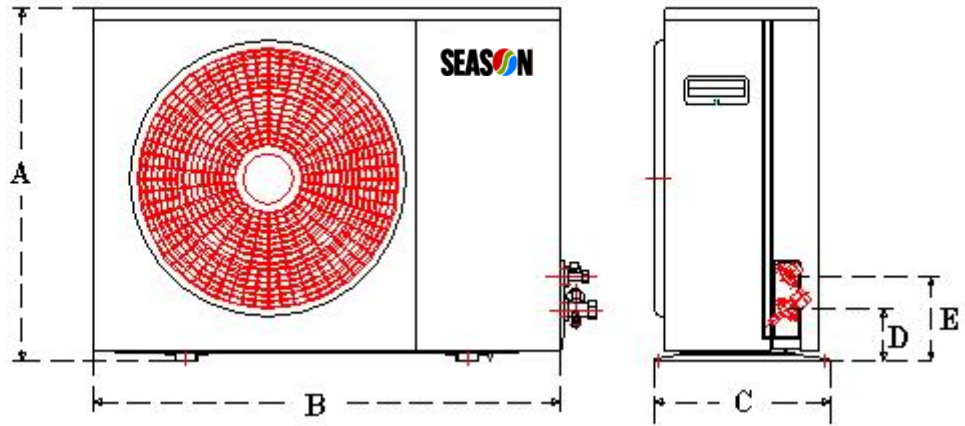

Model	Unit Outside Dimensions					Valve Size(Inch)	
	A	B	C	D	E	Liq.	Gas
CCAG-18-DFN	31.3	37.4	12.6	3.8	6.2	3/8	5/8
CCAG-24-DFN	31.3	37.4	15.4	3.8	6.2	3/8	5/8
CCAG-30-DFN	37.4	37.4	15.4	3.8	6.2	3/8	5/8
CCAG-36-DFN	47.3	37.4	15.4	3.8	6.2	3/8	5/8
CCAG-48-DFN	47.3	37.4	15.4	3.8	6.2	1/2	3/4
CCAG-60-DFN	48.3	37.4	15.4	3.8	6.2	1/2	3/4



**ESPI TECH, 680H Industrial Ct., Chesterfield, MO 63005**  
**Tel: (636) 536-9446 Fax: (636) 536-9441**  
**Email: [info@espitechllc.com](mailto:info@espitechllc.com) Web Site: [www.espitechllc.com](http://www.espitechllc.com)**

**SE0030106**